

# WPL8160 Weigh Price Labeller

Combining faster speeds with finer print quality.



If you need accurate, high speed weigh price labelling with longer running times, look no further than the **WPL8160**. It's specifically designed to handle small to medium size retail packs where, typically, high packing speeds of 160 packs/min are required.

Speed alone, however, is not enough because the weighing of every pack is vital to consistently efficient processing and production and this is where the **WPL8160** excels.

To ensure that every pack is pitched correctly across the weigh table, driven side belts provide positive control and correct orientation of incoming packs. These, along with side guides that are manually adjusted to set the pack width at the input of the machine, ensure product runs true and correctly spaced over the weigh table.

The machine can regulate its own speed according to product input.

#### **Longer running with less downtime**

The **WPL8160** can accept label reels of 320mm diameter which, in addition to increasing the usable number of labels per reel over standard reel diameters by as much as 20%, significantly reduces operator supervision time. **WPL8160** can also be configured to automatically switch over between two labellers when the label reel is exhausted, thereby effectively reducing downtime to zero.

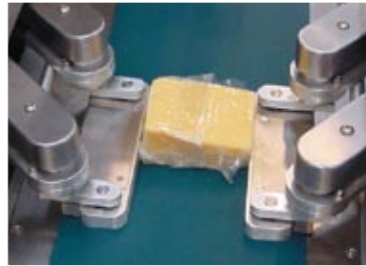

Motor driven centralising system ensures packs are correctly orientated prior to label application. This unit guarantees a high level of first time correct label placement.





The versatile non-contact applicator allows a wide range of labels to be used with minimum changeover time.



## Features and Benefits

- Up to 160 packs/min.
- Motor driven side belt infeed.
- High resolution imaging with 12 dot/mm print head.
- Centralising unit for ensuring pack orientation.
- Optional twin label head capability with automatic changeovers.
- Motorised labelling head height adjustment.
- Left or right hand product flow.
- Optional base labelling with full printing capabilities.
- Ability to accept 320mm label reel stock sizes.
- Ability to rotate the labelling head through 180°
- Pack Sizes:

(mm)	length	width	height
Minimum	80	60	10
Maximum	200	180	150

### Weighing

- Continuous flow dynamic weighing system.
- Switchable weight ranges:

Metric	Min: 20g to 1500g x 1g
	Max: 40g to 1500g x 2g
Cental	0.20lb to 3.3lb x 0.01lb

- Automatic zero tracking.
- Average weight weighing for 'e' - mark to normal and special poultry rules as required.

### Pricing

- Up to 8 digit pricing.
- Variable price rounding to suit territory.
- Discount pricing facility.
- Dual currency capability.

### Labelling

- Complete flexibility of labeller location above or below the belt.
- Automatic changeover between labellers when label stock is exhausted.
- Automatic labeller selection dependent on product.
- Multiple labels can be applied to any pack.
- Complete label layout flexibility.
- Graphics include boxes, lines and bitmaps.
- Extensive independent label fields.
- Maximum label size 100mm long x 100mm wide.
- EAN13, EAN8, Code 39, Code 128, EAN128 barcodes.
- Wide range of character font styles.
- Up to 1000 label format memory.
- Non-contact adjustable label application.
- Motorised adjustable labeller height.

# WPL8160 Weigh Price Labeller

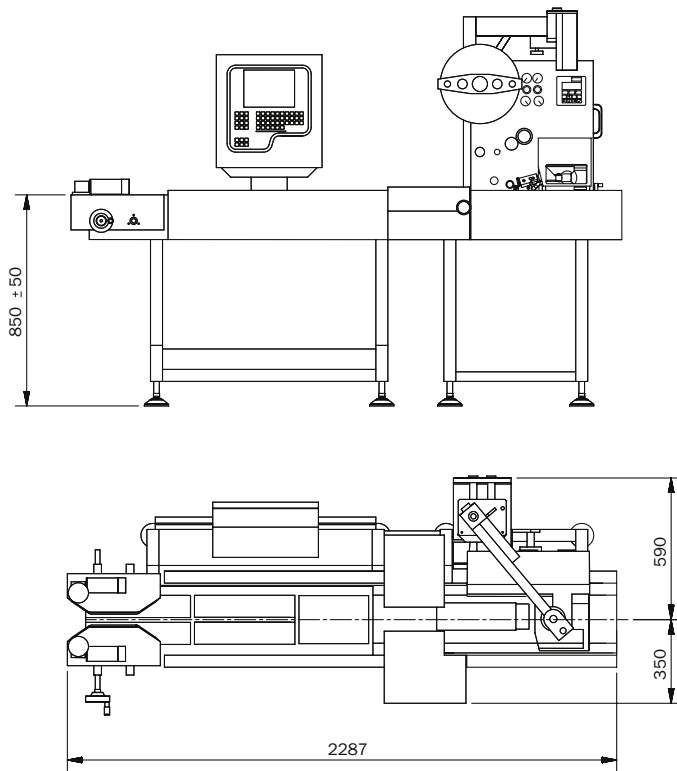

## Technical Information

**Power requirement:** 110/230V ± 10%

**Compressed air:** 130 l/min @ 6 bar

### Optional features

Up to eight label heads with over and under capabilities

### Communications

Three serial ports, independently selectable from RS232, RS422 and multi-drop RS485

Ability to extract real-time running data

Can update label data when machine is running

Can extract totals and average weight logging data

Can receive new labels and bitmaps from remote equipment

### Standard Features

Pack centralising system

Motor driven pack pitching infeed belts

12 dot/mm character imaging print head

Brushless DC motor driven belt conveyor

Stainless steel construction

All AEW Delford Systems machines carry CE certification.

### Integrated Systems

The **WPL8160 Weigh Price Labeller** can operate as a stand alone machine or it can be integrated with a range of manual or automatic production lines.

For further information please logon to: [www.aewdelford.com](http://www.aewdelford.com)